

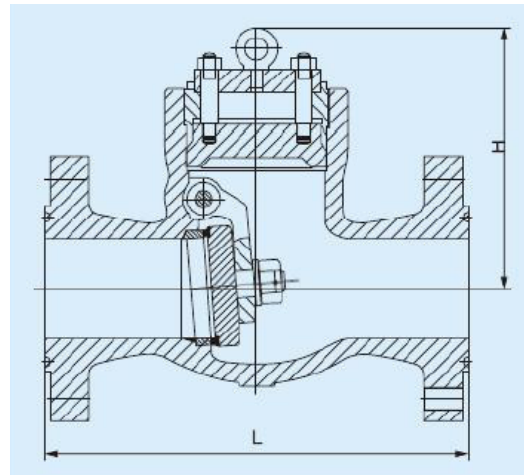

1500LB API Flange Cast Steel Swing Type Check Valve



Parameters

Pressure CLASS	Size		Main Dimensions				Weight(KG)		Cv
	mm	in.	L(RF)	L(BW)	L(RJ)	H	RF	BM	
1500	50	2	368	216	371	225	68	48	—
	65	2-1/2	419	254	422	240	97	65	—
	80	3	470	305	473	254	112	90	240
	100	4	546	405	549	279	177	115	425
	150	6	705	559	711	405	395	250	1000
	200	8	832	711	841	567	710	470	1750
	250	10	991	864	1000	585	1210	800	2735
	300	12	1130	991	1146	630	1970	1350	3990
	350	14	1257	1067	1276	750	2600	1800	4800
	400	16	1384	1194	1407	787	3250	2200	6265
	450	18	1537	1537	1559	885	3960	2600	8255
	500	20	1664	1664	1686	960	4400	2700	10350
600	24	1943	1943	1972	1120	6800	4100	14865	

Wenzhou Kerui Valve Industry Co., LTD

Address:

No.1 Tantou Village, Yongqiang High-tech Park, Longwan District, Wenzhou City, China

Post Code: 328024

Tel: +86-577-86928881 / +86-577-86990007

Fax: +86-577-86912312

E-mail: sale@createvalve.com / offer@createvalve.com